

D²T² Analysis Of Loss of Main Feed Water Accident

Silvia Tolo^a, John Andrews^a

^aUniversity of Nottingham, Nottingham, U.K.

Organiser use only: Received date; revised date; accepted date

Keywords: Nuclear Safety, Boiling Water Reactor, Loss of Main Feed Water, Fault Tree, Event Tree, Dependency Analysis

The Dynamic and Dependent Tree Theory (D²T²) (Andrews and Tolo, 2022) allows to model complex features of dynamic systems behaviour that contradict the assumptions of FT/ET analysis and cannot be included in traditional safety modelling (Tolo and Andrews, 2022). In this study, the D²T² methodology is applied to the analysis of the loss of main feed water accident of the Boiling Water Reactor (BWR) in Fig.1. The results are compared with traditional ET/FT analysis, and the advantages and drawbacks of the approach discussed.

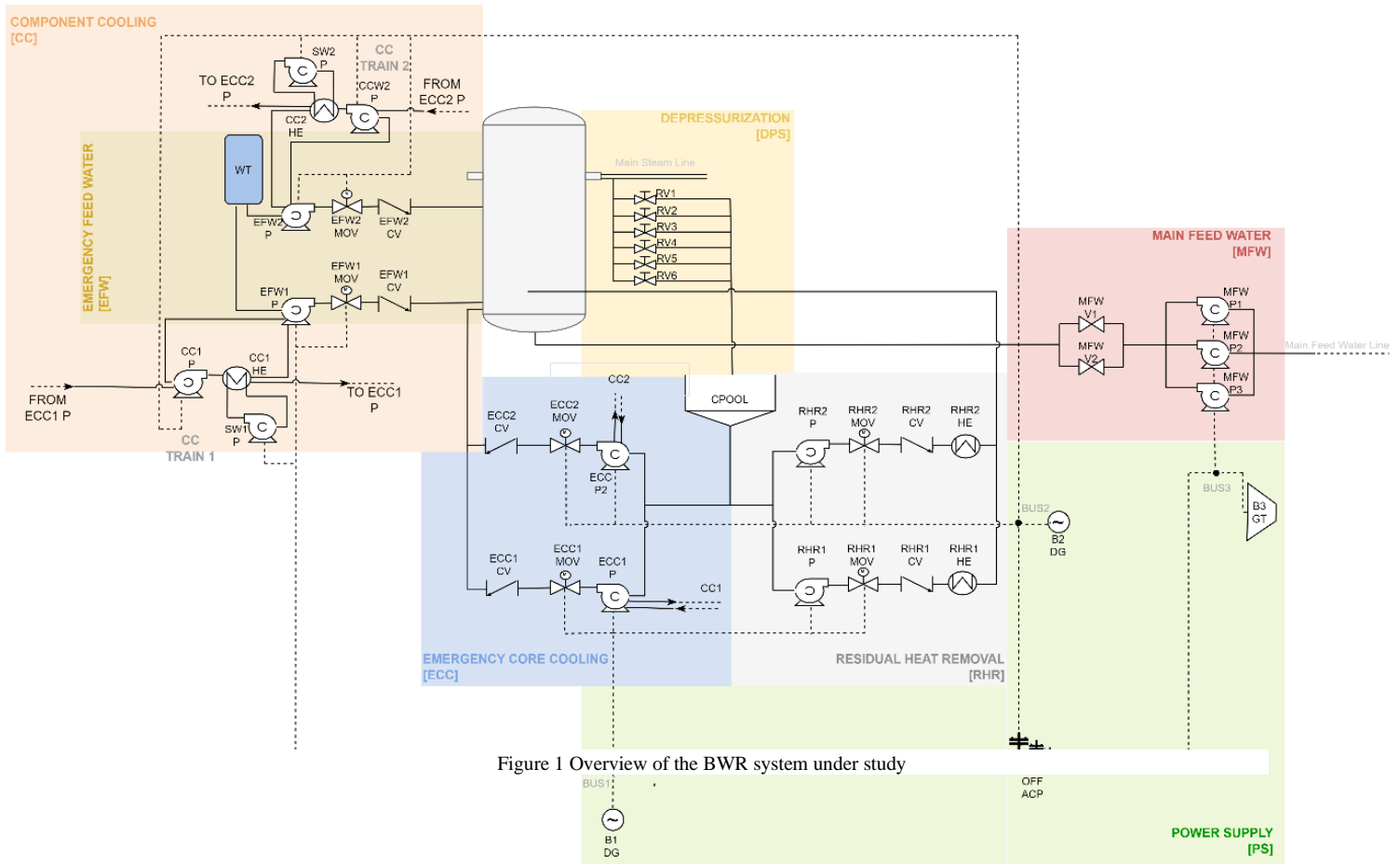

Figure 1 Overview of the BWR system under study

1. SYSTEM DESCRIPTION

As shown by the ET in Fig.2, the accident sequence investigated is triggered by failure of the main feed water system and involves the interaction of seven main subsystems:

- Main Feed Water System (MFW): provides the cooling of the reactor during normal operation.
- Emergency Feed Water System (EFW): activated in the case of failure of the main feed water system.
- Depressurization Systems (DPS): activated in the case of failure of the previous systems in order to decrease the reactor pressure to a range suitable for the operation of low-pressure cooling systems.

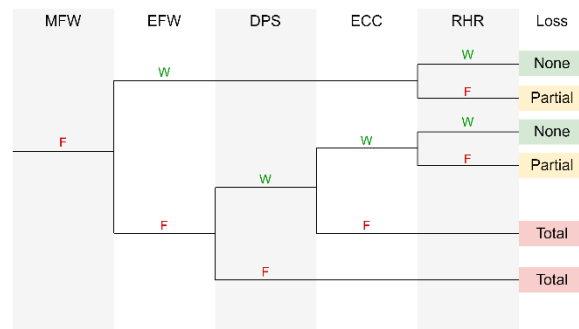

Figure 2 ET model of the loss of main feed water accident

- Emergency Core Cooling System (ECC): designed to provide adequate reactor cooling under low-pressure condition in the case of failure of the MFW and EFW systems;
- Residual Heat Removal System (RHR): provides reactor cooling in low-pressure conditions and after shutdown.

2. NUMERICAL APPLICATION

The structure of the system, as well as the asset management strategies adopted, introduce a series of dependencies in the model, which are processed by the D²T² approach.

These can be classified in three categories:

- Dependencies between components: imply dependencies among FT basic events and their modelling through the use of dynamic solutions (e.g., Markov Model, Petri Nets, etc.). The joint probability values obtained from the dynamic models is then re-introduced in the overall FT framework which is finally computed using novel computational algorithms (Tolo and Andrews, 2023).
- Dependencies between trains: translate into dependencies between FT subtrees, for instance due to standby redundancy or coordinated maintenance strategies. The relative subtrees are converted in equivalent complex events and analysed in order to extract dynamic reliability metrics to be implemented in the dynamic modelling of the dependencies, enabling the application of the same procedure adopted for the modelling of basic event dependencies.
- Dependencies between subsystems: refer to the sharing of resources between subsystems (e.g., support systems, power supply etc.) and hence trigger dependencies between multiple FTs. Within the D²T² framework, such dependencies are computed in the ET analysis through conditioning: the state of the dependency source (e.g., operational state of power supply) is explicitly instantiated so that the failure probabilities associated with the subsystems involved becomes independent, allowing for traditional computation algorithms.

The procedures listed are described and discussed throughout their application to the individual complex features identified within the system model. The results are finally compared with those obtained by traditional ET/FT as well as with fully dynamic models, in order to verify the efficiency and accuracy of the analysis.

Acknowledgements

This work was supported by the Lloyd's Register Foundation, a charitable foundation in the U.K. helping to protect life and property by supporting engineering-related education, public engagement, and the application of research.

References

- Andrews, J., & Tolo, S. (2023). Dynamic and dependent tree theory (D2T2): A framework for the analysis of fault trees with dependent basic events. *Reliability Engineering & System Safety*, 230, 108959.
- Tolo, S., & Andrews, J. (2023). Fault Tree analysis including component dependencies. *IEEE Transactions on Reliability*.
- Tolo, S., & Andrews, J. (2022). An integrated modelling framework for complex systems safety analysis. *Quality and Reliability Engineering International*, 38(8), 4330-4350.